

PAPER • OPEN ACCESS

The effect of dogbones on the behaviour of a castellated steel beam under cyclic loads

To cite this article: R Firman *et al* 2020 *IOP Conf. Ser.: Earth Environ. Sci.* **419** 012065

View the [article online](#) for updates and enhancements.

ECS
The Electrochemical Society
THE KOREAN ELECTROCHEMICAL SOCIETY

The best technical content in electrochemistry and solid state science and technology!

Available until November 9, 2020.

PRIME™
PACIFIC RIM MEETING
ON ELECTROCHEMICAL
AND SOLID STATE SCIENCE
2020

REGISTER TO ACCESS CONTENT FOR FREE! ▶

The effect of dogbones on the behaviour of a castellated steel beam under cyclic loads

R Firman¹, M Amin¹, H Parung¹, R Irmawaty¹, A A Amiruddin¹

¹Department of Civil Engineering, Hasanuddin University, Makassar, Indonesia

E-mail: Rita_irmaway@yahoo.com

Abstract. The plastic moment capacity of castellated steel beams should be reduced to lower the Mpl beam. Higher Mpl beam will require bigger column section to avoid failure/yielding in the column section. The research aims to analyse the behaviour of beams ductility of castellated steel beams using “dogbones.” The research used four types of test beam to check the influence of “dogbones” that are made of steel beams IWF 150 x 100 x 5 x 7. They are normal castellated steel beam, variation in the length of dogbones, and variation in the deep of dogbones. The results show that the plastic moment capacity of castellated beams is higher than normal beam. It is, therefore, necessary to reduce the plastic moment capacity of castellated steel beam by using “dogbones.” It will maintain ductile behaviour of the steel structure. Concrete was discussed.

1. Introduction

The use of steel as a structural member in the structure is quickly becoming attractive today. In steel structures, the pre-engineered building concept (PEB) is most popular because of its ease and simplicity in construction. Such pre-engineered buildings have very large spans but are relatively less charged. So, in general, steel parts are safe in terms of strength. However, parts do not meet serviceability requirements. So, it becomes important to use the beam more deeply so that it meets this requirement. The use of the hollow web or open web beams is the best solution to overcome this difficulty. Perforated web beams are also referred to as castellated beams when perforations are made of hexagonal or square shapes and are equipped with circular openings called cellular beams. The main advantage of using castellated beams is a reduction in the total weight of the structure and quantity of steel that is less. Castella beams are made of standard I-shaped steel by cutting the web on a half-hexagonal line in the centre of the beam. Both parts are moved with one space and then rejoined by welding.

Reduced Beam Section (RBS) is a reduction in flange area with a certain distance from the pedestal. This reduction process is done so that all yielding and plastic joints occur in this RBS section. Besides, the reduction in the area also plays a role in reducing the moment in the column while controlling the occurrence of inelastic deformation in the column. The ability of a structure or structural component not to suddenly collapse (brittle) but still be able to experience considerable deformation when the maximum load is reached before the structure undergoes collapse is called ductility. This report is intended to determine the ductility ability of castellated beams that are given RBS with dogbones form and as a comparison using castellated beams that use RBS with radius form.

2. Design Methods



Content from this work may be used under the terms of the [Creative Commons Attribution 3.0 licence](https://creativecommons.org/licenses/by/3.0/). Any further distribution of this work must maintain attribution to the author(s) and the title of the work, journal citation and DOI.

2.1. Previous Research

- Normal Castellated Beam

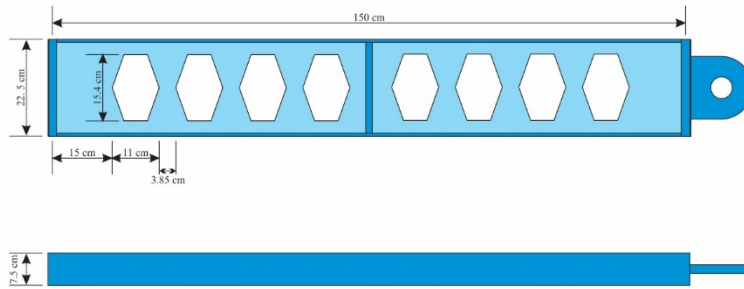

- Castellated Beam with RBSC-1

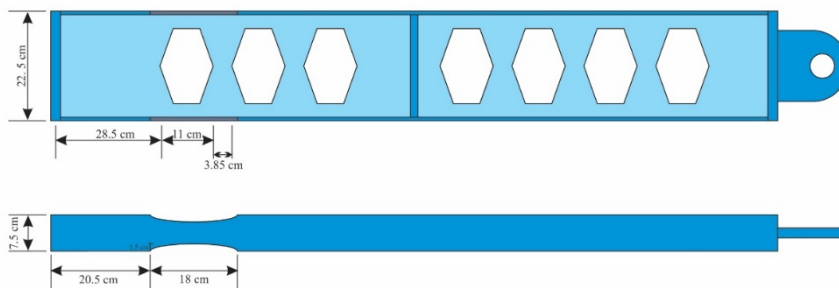

- Castellated Beam with RBSC-2

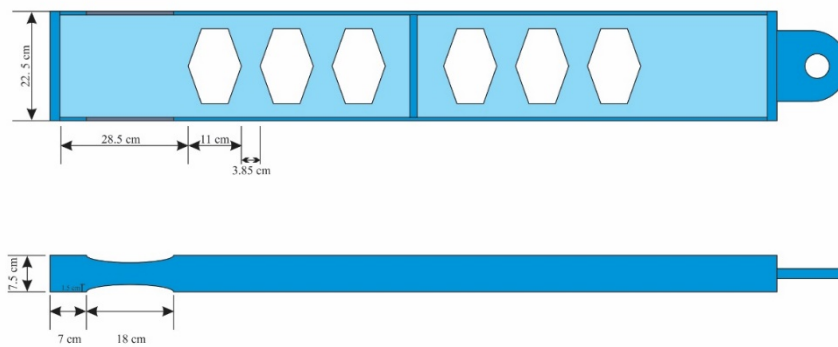
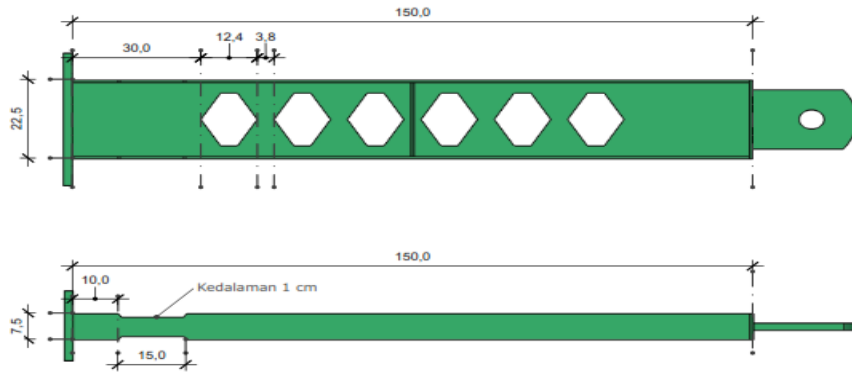

Figure 1. Castellated beam designs of previous research.

2.2. Latest Research

- Castellated Beam with RBSC-1



- Castellated Beam with RBSC-2

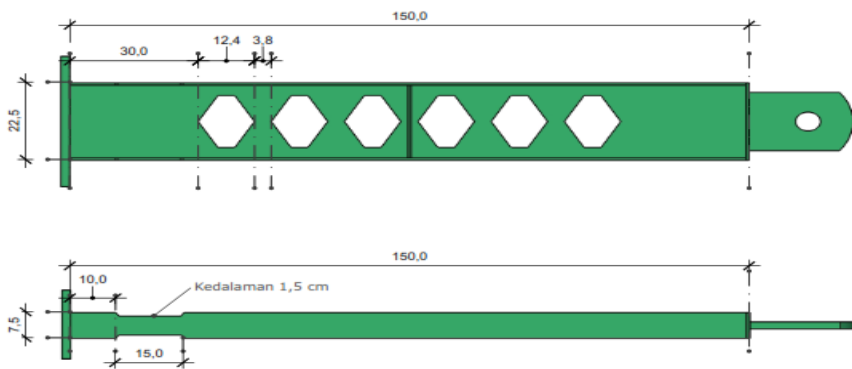

- Castellated Beam with RBSC-3

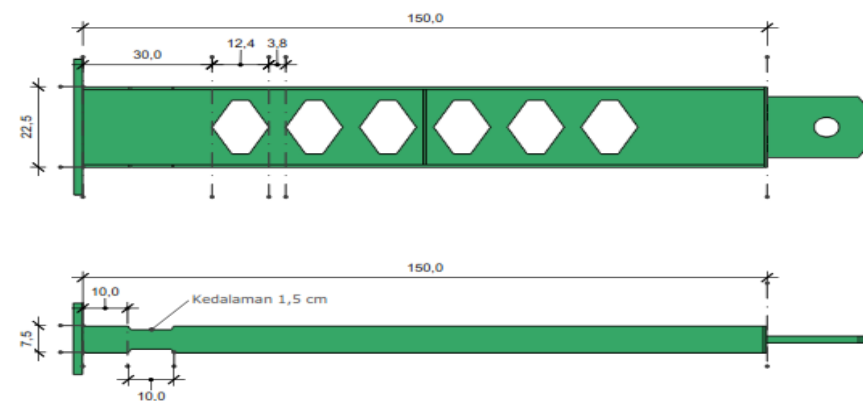

Figure 2. Castellated beam designs of the latest research.

3. Experimental Program

Loading is done back and forth with hydraulic jack and load cell in stages according to the large displacement value at the first yielding (Δ_y) of the analysis results with a value of 20 mm [1]. Determination of the amount of displacement (yielding point) for each cycle, namely $0.25\Delta_y$, $0.5\Delta_y$,

0.75 Δy , Δy , and 2 Δy , 3 Δy and so on until the termination of the load when there is a decrease in the load value from the previous peak (collapse) Gravity loads remain constant, cyclic lateral loads are then provided with an initial displacement rate of 0.05 mm / sec [2, 3].

This study is intended to test the structural capabilities with exterior-interior models using castellated beams that have been given RBS in the "Dogbones" model in the flange [4, 5]. This study compares the ductility behaviour of previous studies in the form of castella beam with RBS Radius shape with RBS in "Dogbones" model [6, 7]. This experiment was designed with the exterior and interior column beam models with cyclic loads, and the results of structural tests were read using LVDT and recorded onto a computer in the form of data.



Figure 3. Model of experimental test.

4. Results and Discussion

4.1. Previous Research

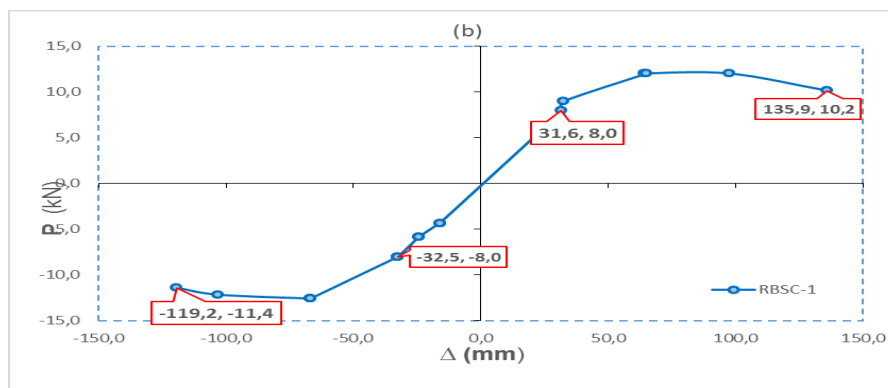

Figure 4. First yielding and the maximum point of the backbone curve of the pull and push area of RBSC-1.

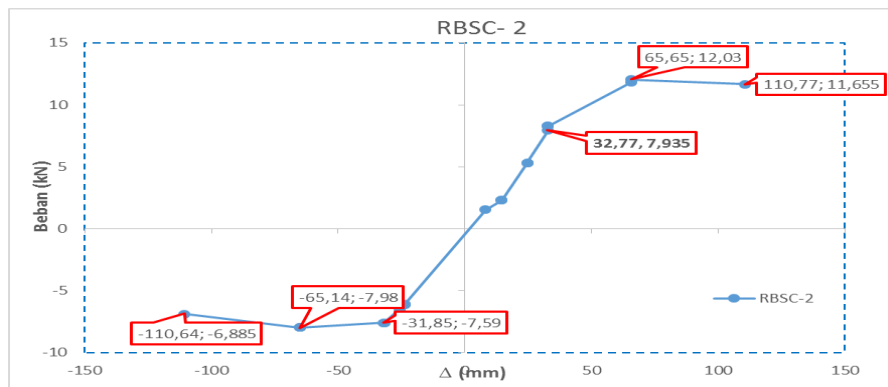

Figure 5. First yielding and the maximum point of the backbone curve of the pull and push area of RBSC-2.

4.2. Latest Research

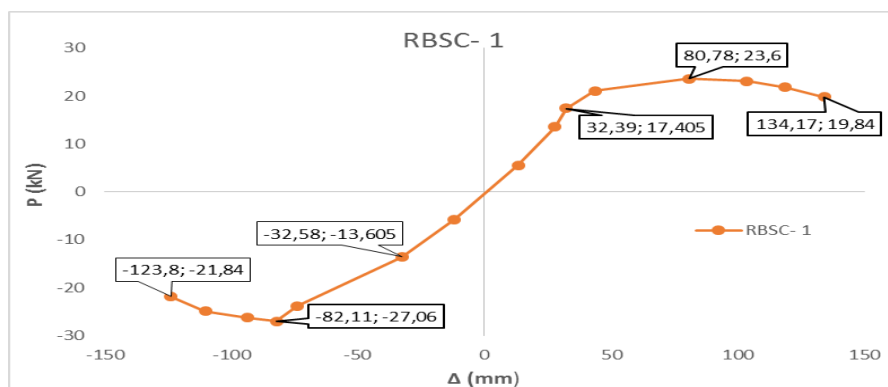

Figure 6. First yielding and the maximum point of the backbone curve of the pull and push area of RBSC-1.

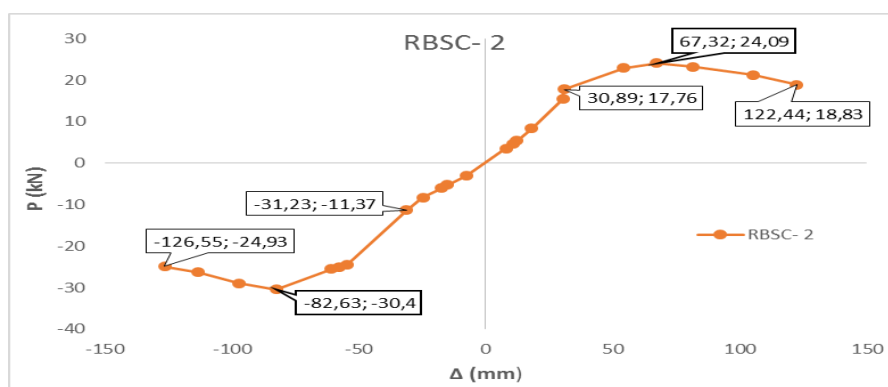

Figure 7. First yielding and the maximum point of the backbone curve of the pull and push area of RBSC-2.

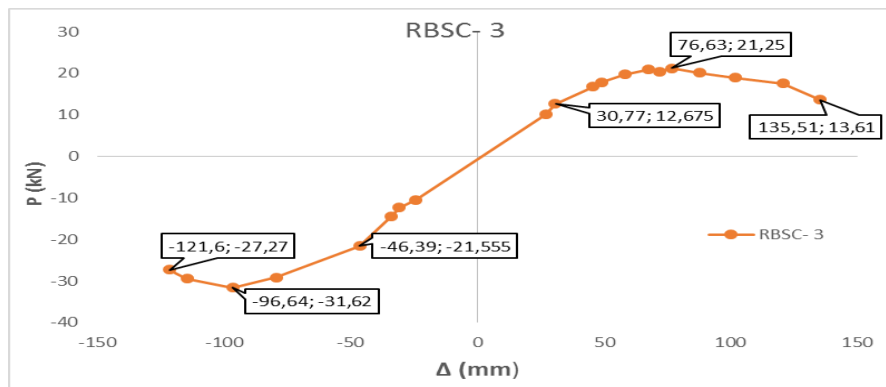

Figure 8. First yielding and the maximum point of the backbone curve of the pull and push area of RBSC-3.

Table 1. Result of previous research.

Tets beam type	Load (P)				Displacement (Δ)				μ		μ average
	Py (kN)		Pu (kN)		Δy (mm)		Δu (mm)		+	-	
	+	-	+	-	+	-	+	-	+	-	
Normal Castellat	9.0	9.0	11.0	14.34	32.86	32.82	136.35	133.27	4.10	4.00	4.05
Castella RBS 1	8.0	8.0	10.2	11.4	31.6	32.5	136.0	119	4.30	3.7	4.00
Castella RBS 2	7.9	7.6	11.7	7.0	32.77	31.85	110.8	110.6	3.40	3.5	3.40

Table 2. Result of the latest research.

Test Beam Type	Load (P)				Displacement (Δ)				μ		μ average
	Py (kN)		Pu (kN)		Δy (mm)		Δu (mm)		+	-	
	+	-	+	-	+	-	+	-	+	-	
Normal Castella	9.0	9.0	11.0	14.34	32.86	32.82	136.35	133.27	4.10	4.00	4.05
Castella RBS 1	17.4	13.6	19.8	21.84	32.39	32.18	134.1	123.8	4.14	3.85	4.00
Castella RBS 2	17.8	11.4	17.8	11.37	30.89	31.23	122.4	126.5	3.96	4.05	4.01
Castella RBS 3	12.8	14.4	19.8	21.84	30.77	33.86	135.5	121.6	4.40	3.59	4.00

There is a difference in ductility between castellated beams with RBS in the form of radius and castellated with RBS in the form of dog bones where castellated beams with RBS in the form of dog bones has higher ductility.

5. Conclusions

The plastic moment capacity of castellated beams is higher than the normal beam. It is, therefore, necessary to reduce the plastic moment capacity of the castellated steel beam by using “dogbones.” It will maintain ductile behaviour of the steel structure. Concrete was discussed.

Acknowledgements

Authors wishing to acknowledge assistance or encouragement from colleagues, special work by technical staff, or financial support from organisations should do so in an unnumbered Acknowledgments section immediately following the last numbered section of the paper.

References

- [1] AISC A 2010 *Prequalified connections for special and intermediate steel moment frames for seismic applications* (Chicago: American Institute of Steel Construction, AISC)
- [2] AISC A 2010 *Specification for steel building* (Chicago: American Institute of Steel Construction, AISC)
- [3] Kim T, Whittaker A S, Gilani A S J, Bertero V V, Takhirov S M 2002 Experimental evaluation of plate-reinforced steel moment-resisting connections *Journal of structural engineering* **128**(4) 483-491
- [4] Nini A, Parung H, Irmawaty R, and Arwin A, 2016 *RBS performance of kastella beams connected to columns on cyclic load* (Makassar: Civil Engineering Hasanuddin University)
- [5] Nini A, Parung H, Irmawaty R, and Arwin A 2017 *Effects of RBS Position on castella beam on ductility* (Makassar: Civil Engineering Hasanuddin University)
- [6] Nini A, Parung H, Irmawaty R, and Arwin A 2017 *Performance of Kastella Beam Structures with RBS method on Cyclic Load* (Makassar: Civil Engineering Hasanuddin University)
- [7] Nini A, Parung H, Irmawaty R, and Arwin A 2017 Distance Optimization of Kastella Beams Connected with Columns in Cyclic Load *CONTEXT* **11** 91 - 99